

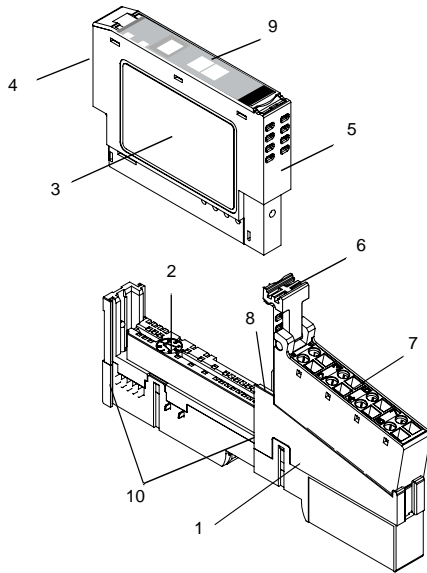

Helm Instrument Company, Inc.
 361 West Dussel Drive
 Maumee, Ohio 43537 USA
 419/ 893-4356
 Fax: 419/ 893-1371
 www.helminstrument.com

Installation Instructions HM1734-WM-2HR POINT I/O Strain Gage Input Module 2/11/2019



	Description		Description
1	Mounting Base ¹	6	RTB Removal Handle
2	Mechanical Keying (orange)	7	Removable Terminal Block (RTB) ¹
3	Module Wiring Diagram	8	DIN Rail Locking Screw (orange)
4	Module Locking Mechanism	9	Slide-in Writable Label
5	Insertable I/O Module	10	Interlocking Side Pieces

¹ Wiring Base Assembly consists of item 1) mounting base, 1734-MB and item 7) removable terminal block, 1734-RT or -RTS.

POINT I/O is a trademark of Rockwell Automation
 DeviceNet is a trademark of ODVA, Inc.

February, 2019

This Series C product can be used with DeviceNet and PROFIBUS adapters. It can be used with Ethernet/IP and Ethernet adapters using RSLogix 5000, version 11 (or higher) software.

Important User Information

Because of the variety of uses for the products described in this publication, those responsible for the application and use of these products must satisfy themselves that all necessary steps have been taken to assure that each application and use meet all performance and safety requirements, including any applicable laws, regulations, codes and standards. In no event will Allen-Bradley be responsible or liable for indirect or consequential damage resulting from the use or application of these products.

Any illustrations, charts, sample programs, and layout examples shown in this publication are intended solely for purposes of example. Since there are many variables and requirements associated with any particular installation, Allen-Bradley does not assume responsibility or liability (to include intellectual property liability) for actual use based upon the examples shown in this publication.

Allen-Bradley publication SGI-1.1, *Safety Guidelines for the Application, Installation and Maintenance of Solid-State Control* (available from your local Allen-Bradley office), describes some important differences between solid-state equipment and electromechanical devices that should be taken into consideration when applying products such as those described in this publication.

Reproduction of the contents of this copyrighted publication, in whole or part, without written permission of Rockwell Automation, is prohibited.

Throughout this publication, notes may be used to make you aware of safety considerations. The following annotations and their accompanying statements help you to identify a potential hazard, avoid a potential hazard, and recognize the consequences of a potential hazard.

WARNING

Identifies information about practices or circumstances that can cause an explosion in a hazardous environment, which may lead to personal injury or death, property damage, or economic loss.

ATTENTION



Identifies information about practices or circumstances that can lead to personal injury or death, property damage, or economic loss.

IMPORTANT

Identifies information that is critical for successful application and understanding of the product.

ATTENTION**Environment and Enclosure**

This equipment is intended for use in a Pollution Degree 2 industrial environment, in overvoltage Category II applications (as defined in IEC publication 60664-1), at altitudes up to 2000 meters without derating.

This equipment is considered Group 1, Class A industrial equipment according to IEC/CISPR Publication 11. Without appropriate precautions, there may be potential difficulties ensuring electromagnetic compatibility in other environments due to conducted as well as radiated disturbance.

This equipment is supplied as "open type" equipment. It must be mounted within an enclosure that is suitably designed for those specific environmental conditions that will be present and appropriately designed to prevent personal injury resulting from accessibility to live parts. The interior of the enclosure must be accessible only by the use of a tool. Subsequent sections of this publication may contain additional information regarding specific enclosure type ratings that are required to comply with certain product safety certifications.

See NEMA Standards publication 250 and IEC publication 60529, as applicable, for explanations of the degrees of protection provided by different types of enclosure. Also, see the appropriate sections in this publication, as well as the Allen-Bradley publication 1770-4.1 ("Industrial Automation Wiring and Grounding Guidelines"), for additional installation requirements pertaining to this equipment.

ATTENTION

POINT I/O is grounded through the DIN rail to chassis ground. Use zinc plated, yellow chromated steel DIN rail to assure proper grounding. Using other DIN rail materials (e.g. aluminum, plastic, etc.) which can corrode, oxidize or are poor conductors can result in improper or intermittent platform grounding.

WARNING**EXPLOSION HAZARD**

- Do not disconnect equipment unless power has been removed or the area is known to be nonhazardous.
 - Do not disconnect connections to this equipment unless power has been removed or the area is known to be nonhazardous. Secure any external connections that mate to this equipment by using screws, sliding latches, threaded connectors, or other means provided with this product.
 - Substitution of components may impair suitability for Class I, Division 2.
 - If this product contains batteries, they must only be changed in an area known to be nonhazardous.
-

ATTENTION**Preventing Electrostatic Discharge**

This equipment is sensitive to electrostatic discharge, which can cause internal damage and affect normal operation. Follow these guidelines when you handle this equipment:

- Touch a grounded object to discharge potential static.
 - Wear an approved grounding wriststrap.
 - Do not touch connectors or pins on component boards.
 - Do not touch circuit components inside the equipment.
 - If available, use a static-safe workstation.
 - When not in use, store the equipment in appropriate static-safe packaging.
-

Installing the Mounting Base

To install the mounting base on the DIN rail, proceed as follows.

1. Position the mounting base vertically above the installed units (adapter, power supply or existing module).
2. Slide the mounting base down allowing the interlocking side pieces to engage the adjacent module or adapter.
3. Press firmly to seat the mounting base on the DIN rail. The mounting base will snap into place.
4. To remove the mounting base from the DIN rail, remove the module, and use a small bladed screwdriver to rotate the base locking screw to a vertical position. This releases the locking mechanism. Then lift straight up to remove.

Installing the I/O Module

The module can be installed before, or after base installation. Make sure that the mounting base is correctly keyed before installing the module into the mounting base. In addition, make sure the mounting base locking screw is positioned horizontal referenced to the base.

WARNING

When you insert or remove the module while backplane power is on, an electrical arc can occur. This could cause an explosion in hazardous location installations. Be sure that power is removed or the area is nonhazardous before proceeding.

1. Using a bladed screwdriver, rotate the keyswitch (2) on the mounting base clockwise until the number required for the type of module being installed aligns with the notch in the base.
2. Make certain the DIN rail locking screw is in the horizontal position. (You cannot insert the module if the locking mechanism is unlocked.)

3. Insert the module straight down into the mounting base and press to secure. The module will lock into place.

Installing the Removable Terminal Block (RTB)

A removable terminal block is supplied with your wiring base assembly. To remove, pull up on the RTB handle. This allows the mounting base to be removed and replaced as necessary without removing any of the wiring. To reinsert the removable terminal block, proceed as follows.

1. Insert the end opposite the handle into the base unit. This end has a curved section that engages with the wiring base.
2. Rotate the terminal block into the wiring base until it locks itself in place.
3. If an I/O module is installed, snap the RTB handle into place on the module.

WARNING

When you connect or disconnect the Removable Terminal Block (RTB) with field side power applied, an electrical arc can occur. This could cause an explosion in hazardous location installations.

Be sure that power is removed or the area is nonhazardous before proceeding.

Removing a Mounting Base

To remove a mounting base, you must remove any installed module, and the module installed in the base to the right. Remove the removable terminal block (if wired).

1. Unlatch the RTB handle on the I/O module.
2. Pull on the RTB handle to remove the removable terminal block.

When you connect or disconnect the Removable Terminal Block (RTB) with field side power applied, an electrical arc can occur. This could cause an explosion in hazardous location installations.

Be sure that power is removed or the area is nonhazardous before proceeding.

3. Press on the module lock on the top of the module.
4. Pull on the I/O module to remove from the base.

When you insert or remove the module while backplane power is on, an electrical arc can occur. This could cause an explosion in hazardous location installations. Be sure that power is removed or the area is nonhazardous before proceeding.

5. Repeat steps 1, 2, 3 and 4 for the module to the right.
6. Use a small bladed screwdriver to rotate the orange base locking screw to a vertical position. This releases the locking mechanism.
7. Then lift straight up to remove.

OUTPUT TAG DESCRIPTIONS

CALMODE

Used for initial installation. All math is disabled, weigh value is not scaled, leaving raw A/D value.
Value = 2,090,000 to 2,100,000 at normal zero (at rest state).

RUNMODE

A/D values scaled with math in ladder logic
Factory cal setting 100,000 counts = 2MV/V

CLEAR TARE CH1/CH2 Bit

Clears internal tare value for “zero state”.
Useful when troubleshooting load cell wiring or other failures.

TARE CH1/CH2

Sets A/D value to zero.

READ ADTRIM BIT

(HELM Factory setting only).

SET-TO-CH1 Bit

Used for one channel operation where a faster sample speed is required.
1 = 2msec (max speed)
0 = 4msec (max speed-default)

FREQUENCY BITS

Used to set sample rate and filter options.
With no bits set: Sample = 100msec.

Set one bit only.

Note: For one channel operation, sample rate is at bit selected.
For two channel operation, sample rate is 2 times bit time selected.

OUTPUT TAG DESCRIPTIONS

VIBRATION FILTER

Filter ON/OFF Bit

0 = Normal Average

1 = Rolling Average

MSF BITS – (Motion Stabilization Filter)

Used for applications with constant or static type loads to keep display value stable.

MSF1_2 (1 count up – 2 counts down).

MSF2_4

MSF4_8

MSF5_10

Set one bit only.

ZERO-DEAD-BAND Bits

Useful for Auto-Tare functions with production runs.

Set only one bit.

ZEROBAND_025 = .025% full scale

ZEROBAND_05 = .05% full scale

ZEROBAND_075 = .075% full scale

Auto tare occurs when load cell weight is at bit level or lower.

SET AVERAGE SAMPLE Bits

See Required Controller Tags:

HM1734WM1_a[8]

REQUIRED CONTROLLER TAGS

CH1/CH2 SCALE SET

HM1734WM1_a[0]

HM1734WM1_a[3]

Full scale setting for CH1, CH2

Value is determined by capacity of load cell and by resolution required.

Example: 10KG = 10,000

SET AUTOCAL REFERENCE WEIGH VALUE CH1, CH2

HM1734WM1_a[1]

HM1734WM1_a[4]

Enter desired value to read based on known weight from calibrate procedure.

GET WEIGH VALUE CH1, CH2

HM1734WM1_a[2]

HM1734WM1_a[5]

Reports measured weigh value in RUN mode.

Reports raw A/D count value in CAL mode.

SET AUTOCAL CH1, CH2 Enable Bit

HM1734WM1_a[6]

HM1734WM1_a[7]

With ladder logic provided, an auto-cal method for calibrating is available.

Set to (1) to initiate Auto-Cal for the channel.

Ladder logic will clear the bit.

SET AVERAGE SAMPLE COUNT

HM1734WM1_a[8]

Set number of samples to take for average type filter.

Two Channel operation; Max value (50).

One Channel operation; Max value (100).

SET mV/V CH1, CH2

HM1734WM1_b[0]

HM1734WM1_b[1]

CH1/CH2 MV_V Settings

Enter 2.0MV/V for nominal load cell.

Actual value is from load cell specification.

AUTO CAL mV/V

HM1734WM1_b[2]

HM1734WM1_b[3]

Values generated by Auto_Cal routine.

Troubleshooting with the Indicators

Module Status:

Off	No power applied to device.
Green	Device operating normally.
Flashing Green	Device needs commissioning due to configuration missing, incomplete or incorrect.
Flashing Red	Recoverable fault.
Red	Unrecoverable fault. May require device replacement.
Flashing Red/Green	Device is in self-test.

Network Status:

Off	Device is not on-line. Device has not completed dup_MAC_id test. Device not powered. Check module status indicator.
Green	Device on-line and has connections to the established state.
Flashing Green	Device is on-line but has no connections in the established state.
Flashing Red	One or more I/O connections is in timed-out state.
Red	Critical link failure – failed communications device.
Flashing Red/Green	Network access error and is in communication faulted state. Device has received and accepted an Identity Communication Faulted Request – long protocol message.

Specifications - HM1734-WM Strain Gage Input Module

Setup Procedure

A complete listing of a sample ladder logic program is included at the back of this manual.

Examples shown here are for reference.



All values are 0 (default) on initial start-up.

This means that all alarms are disabled.

You must make the following adjustments for proper operation:

- Balance sensor input(s)
- Set Calibration numbers

Follow Steps 1 and 2 for each channel.

Step 1. Balance Sensor Input Check

1. Set to CAL mode.
2. Set Clear Tare bit momentarily.
3. Check Raw A/D value. (Range 2,090,000 to 2,100,000)
CH1 = Controller Tag HM1734WM1-a[2]
CH2 = Controller Tag HM1734WM1-a[5]
4. Set Zero Tare bit momentarily.

Step 2. Set Calibration Numbers

1. Set Scale to capacity of load cell.
2. Set mV/V to load cell specification.

Example:

100 ton load cell, 2.025 mV/V

For scale set, enter 100

For mV/V set, enter 2.025

3. Set to RUN mode.

CALIBRATING WITH KNOWN LOAD (AUTO-CAL)

- 1) Set known weight for channel at scale parameter.
- 2) Set mV/V.
- 3) Tare-0 (with no weight on cell/scale).
- 4) Set module to AUTOCAL mode (BIT).
- 5) Apply known load (test weight) to load cells/ scale.
- 6) Set AUTOCAL bit on for CH1 (CH2 if applicable).
- 7) To ensure accuracy repeat the steps above.
- 8) Toggle "SAVE TO EEPROM" (BIT).
- 9) MAKE SURE AUTOCAL MODE BIT STAYS ON.

SETTING UP HM1734WM MODULE USING 1734-AENT/A on Ethernet/IP

Step #1

Add module to project as following:

HM1734WM MODULE PROPERTIES

General Tab Settings

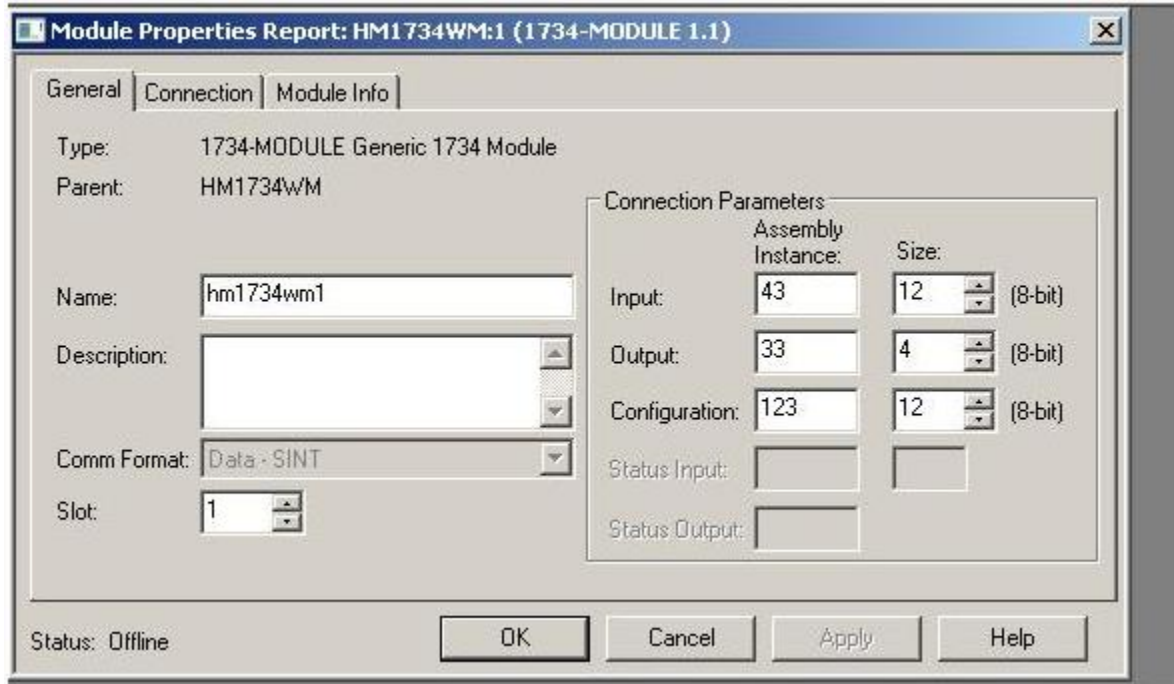

Connection Tab Settings

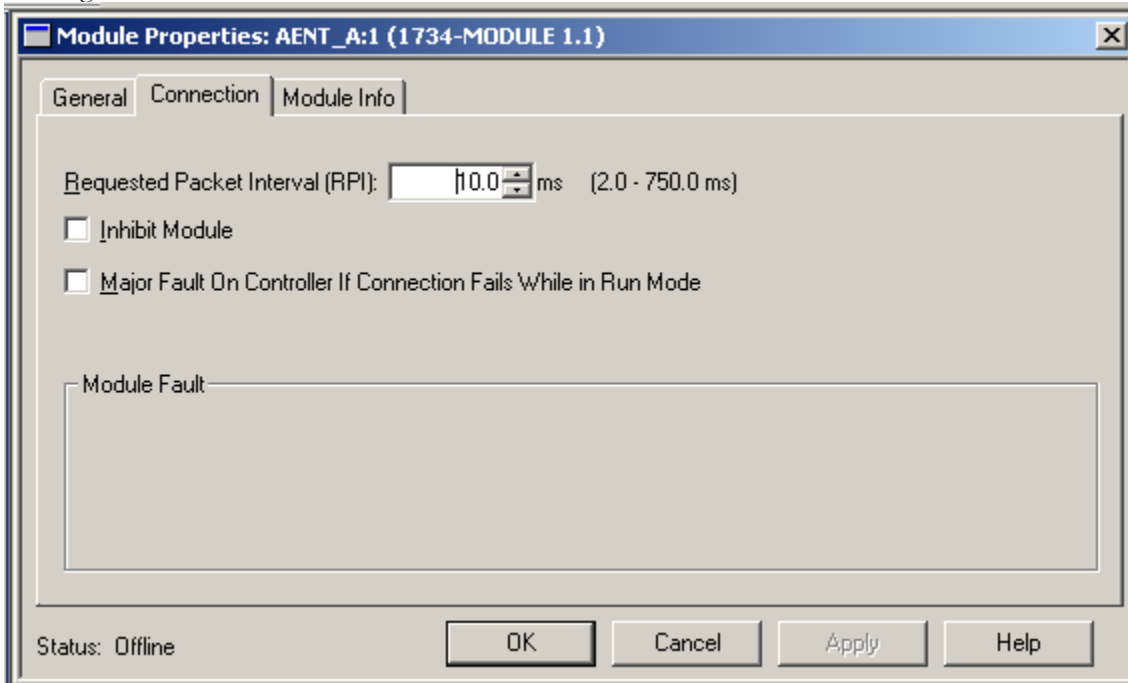

Step #2

- Open "Template" file
- Copy all controller tags
- Open project file
- Paste controller tags
- Duplicates may be created, delete them now

Step #3

- Open "Template" file
- Copy add-on instruction "HM1734WM"
- Open project file
- Paste add-on instruction in add-on's section

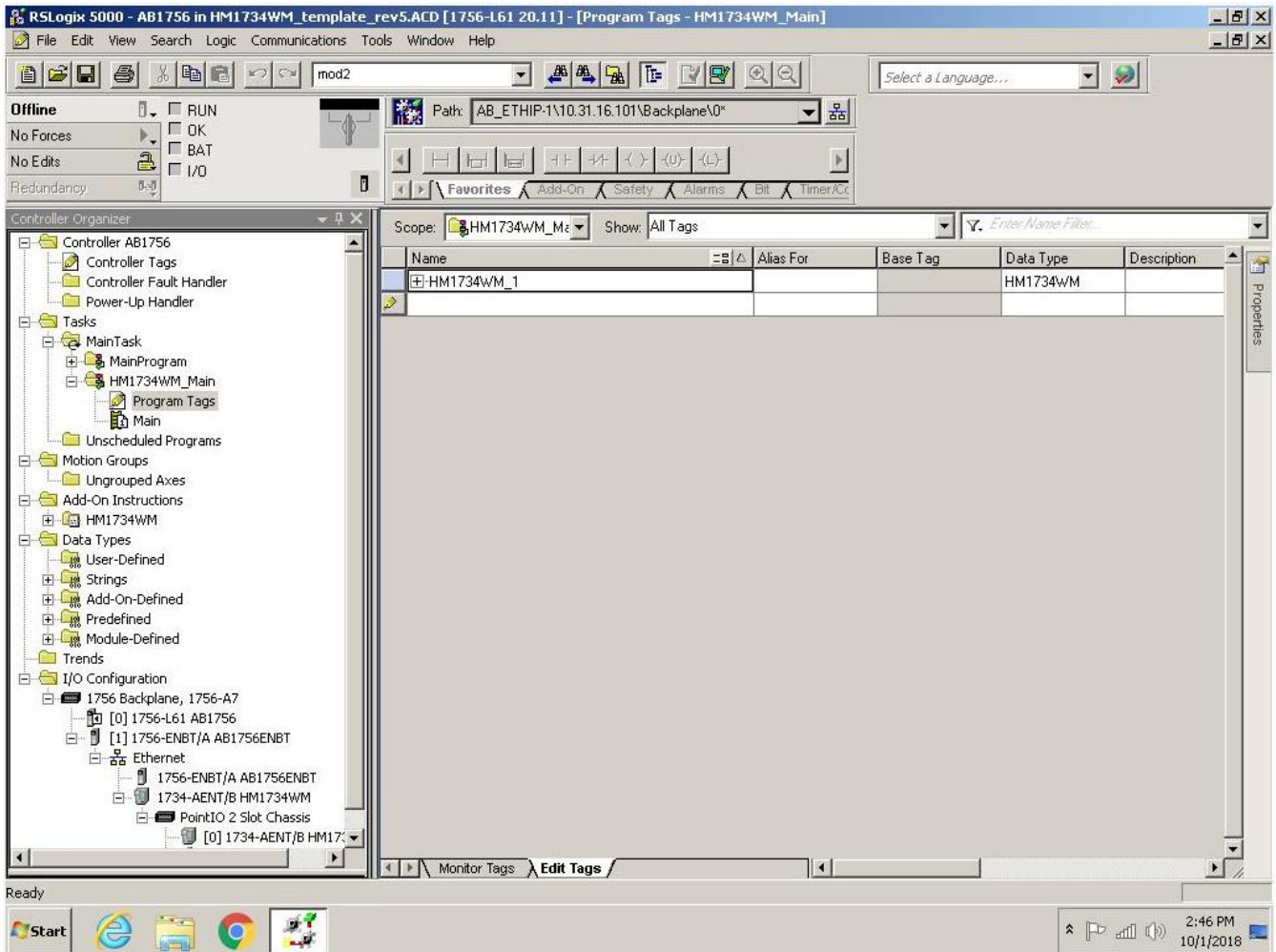

Step #4

- Open "Template" file
- Copy HM1734WM_main routine
- Open project
- Paste HM1734WM_main routine
- Check program tag here should be as Example

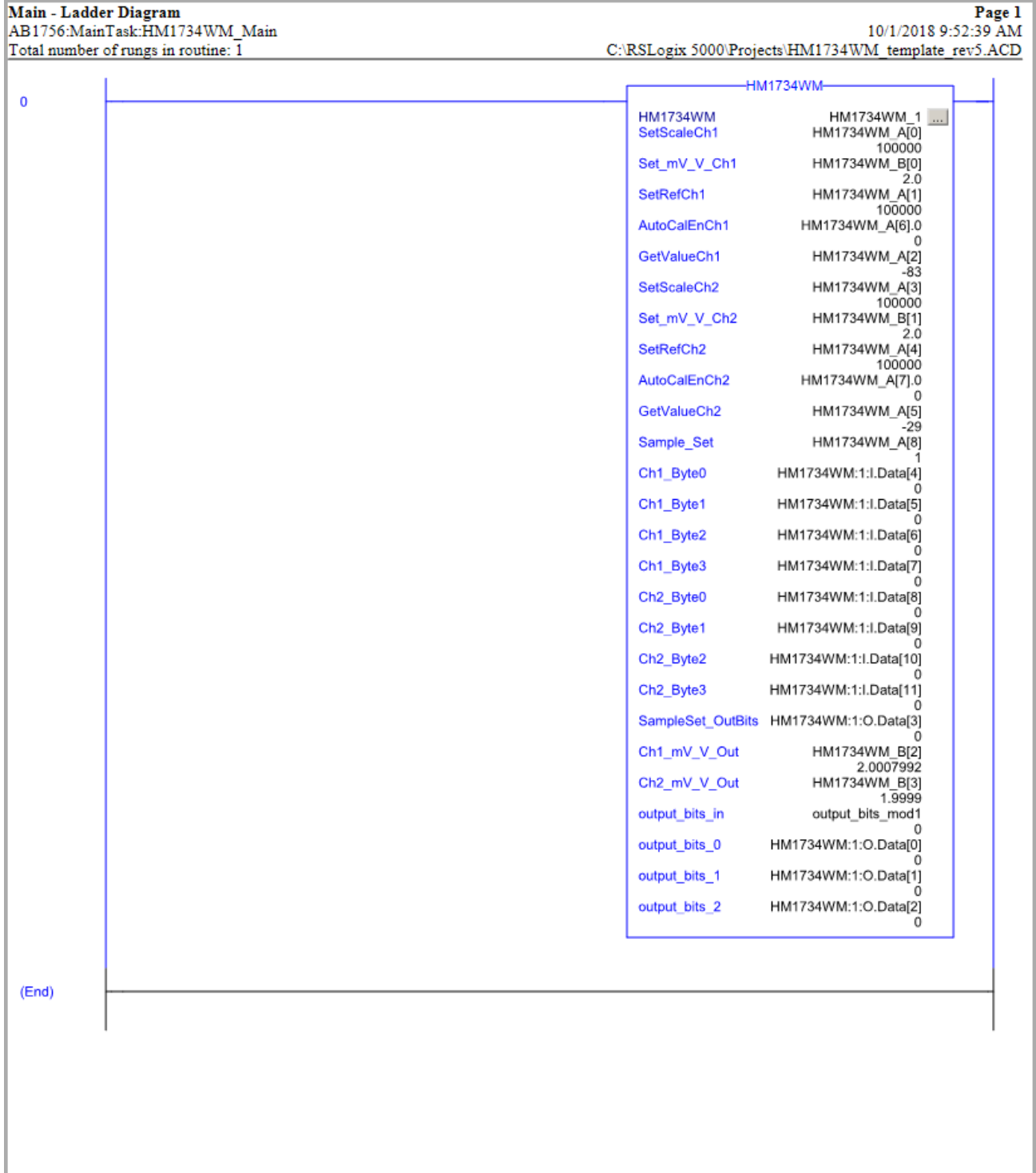

Step #5
 Check routine for entries

Data Map for HM1734-WM on Ethernet/IP

OUTPUT TAGS

[n] = slot number for module		
AENT_A:[n]:O.Data	SINT[4]	Description
Output_bits_mod1.0	bit	Set Cal Mode Bit
Output_bits_mod1.1	bit	Set Run Mode Bit
Output_bits_mod1.2	bit	Ch1 Clear Tare Bit (momentary)
Output_bits_mod1.3	bit	Ch1 Tare Bit (momentary)
Output_bits_mod1.4	bit	Reserved
Output_bits_mod1.5	bit	Read AD Trim Bit (Factory Use Only)
Output_bits_mod1.6	bit	Ch2 Clear Tare Bit (momentary)
Output_bits_mod1.7	bit	Ch2 Tare Bit (momentary)
Output_bits_mod1.8	bit	Reserved
Output_bits_mod1.9	bit	Set ch1_only
Output_bits_mod1.10	bit	Set_to_4ms (Frequency)
Output_bits_mod1.11	bit	Set_to_8ms (Frequency)
Output_bits_mod1.12	bit	Set_to_16ms (Frequency)
Output_bits_mod1.13	bit	Set_to_32ms (Frequency)
Output_bits_mod1.14	bit	Set_to_40ms (Frequency)
Output_bits_mod1.15	bit	Set_to_48ms (Frequency)
Output_bits_mod1.16	bit	Vibration Filter Bit
Output_bits_mod1.17	bit	Set Motion Stabilization Filter (MSF) range from -0.002% to +0.001% of full scale
Output_bits_mod1.18	bit	Set Motion Stabilization Filter (MSF) range from -0.004% to +0.002% of full scale
Output_bits_mod1.19	bit	Set Motion Stabilization Filter (MSF) range from -0.008% to +0.004% of full scale
Output_bits_mod1.20	bit	Set Motion Stabilization Filter (MSF) range from -0.010% to +0.005% of full scale
Output_bits_mod1.21	bit	Set Zero Dead Band to 0.025% of full scale
Output_bits_mod1.22	bit	Set Zero Dead Band to 0.05% of full scale
Output_bits_mod1.23	bit	Set Zero Dead Band to 0.075% of full scale
Output_bits_mod1.24	bit	Average Sample_bit0
Output_bits_mod1.25	bit	Average Sample_bit1
Output_bits_mod1.26	bit	Average Sample_bit2
Output_bits_mod1.27	bit	Average Sample_bit3
Output_bits_mod1.28	bit	Average Sample_bit4
Output_bits_mod1.29	bit	Average Sample_bit5
Output_bits_mod1.30	bit	Average Sample_bit6
Output_bits_mod1.31	bit	Average Sample_bit7

Data Map for HM1734-WM on Ethernet/IP

Required Controller Tags

Data Tags Name	Data Type	
HM1734WM1	DINT[9]	
HM1734WM1_A[0]	DINT	CH1 Set Scale Value
HM1734WM1_A[1]	DINT	CH1 Set AutoCal Reference Weigh Actual Value
HM1734WM1_A[2]	DINT	CH1 Get Weigh Value
HM1734WM1_A[3]	DINT	CH2 Set Scale Value
HM1734WM1_A[4]	DINT	CH2 Set AutoCal Reference Weigh Actual Value
HM1734WM1_A[5]	DINT	CH2 Get Weigh Value
HM1734WM1_A[6]	DINT	CH1 Set AutoCal Enable Bit
HM1734WM1_A[7]	DINT	CH2 Set AutoCal Enable Bit
HM1734WM1_A[8]	DINT	Set Average Sample Count (0-255)
HM1734WM1b	REAL[2]	
HM1734WM1_B[0]	REAL	CH1 Set mV_V
HM1734WM1_B[1]	REAL	CH2 Set mV_V
HM1734WM1_B[2]	REAL	Ch1_Autocal_mV/V
HM1734WM1_B[3]	REAL	Ch2_Autocal_mV/V

Helm HM-1734-WM 6-Wire Weigh Cell Connection

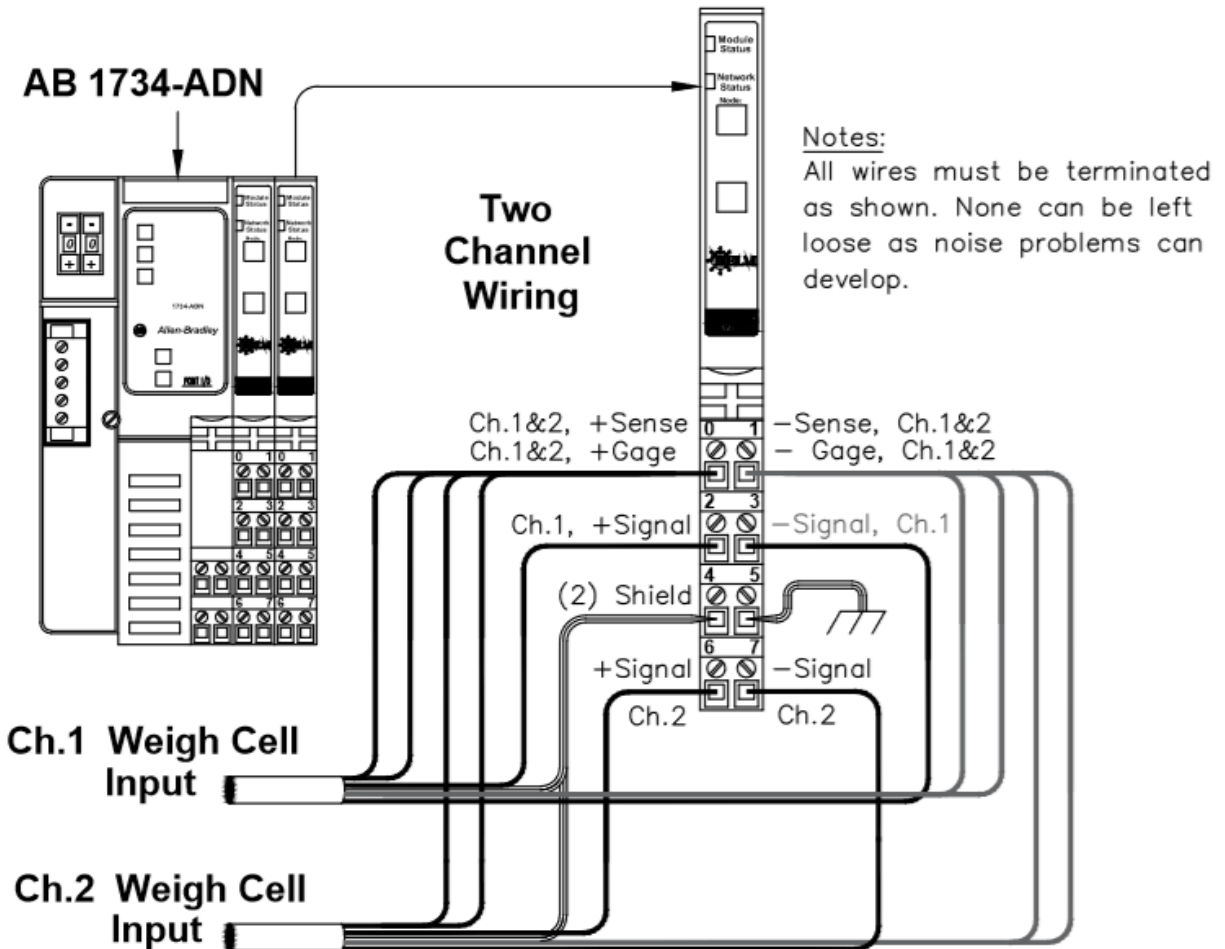

Helm HM-1734-WM 4-Wire Weigh Cell Connection

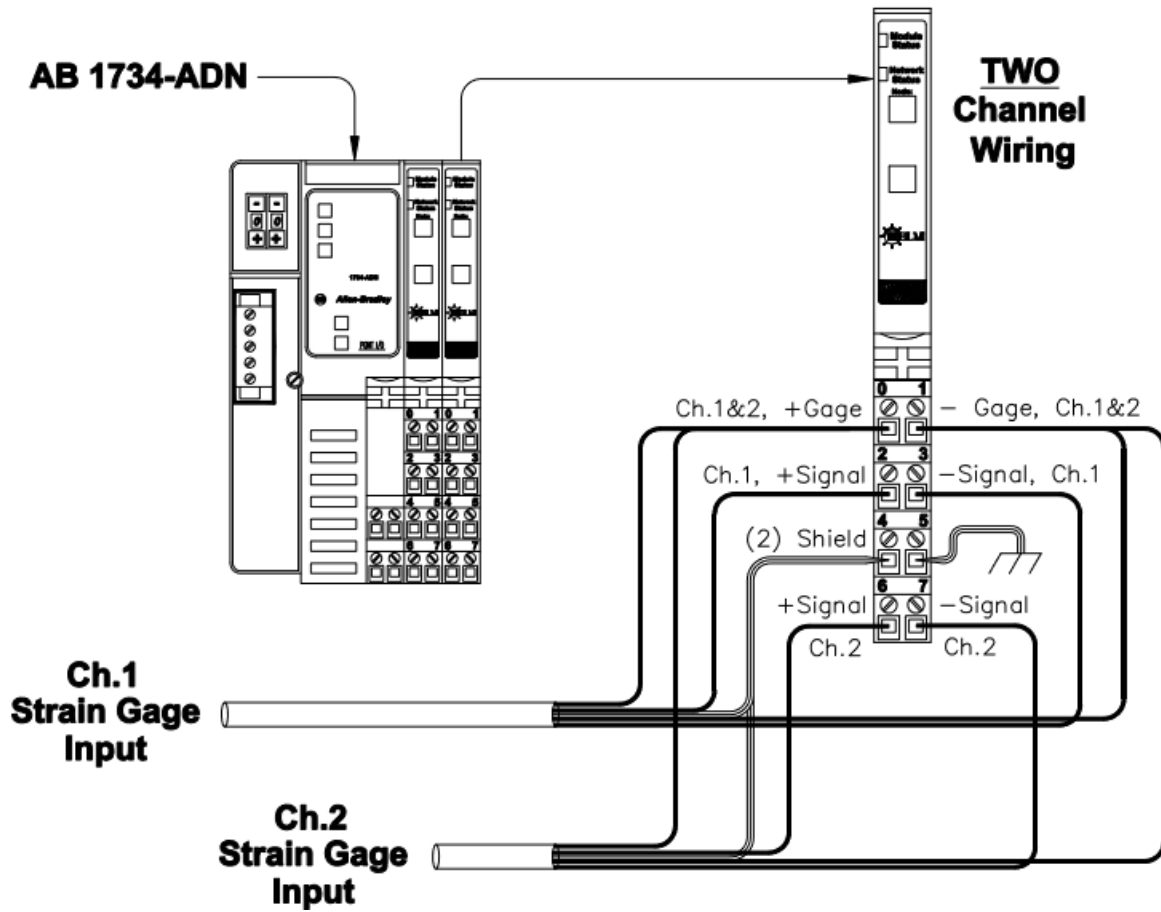

Common Techniques Used in this Manual

The following conventions are used throughout this manual:

- Bulleted lists such as this one provides information, not procedural steps.
- Numbered lists provide sequential steps or hierarchical information.

Product Support

Contact your Helm representative or call Helm direct at 419-893-4356:

- sales and order support
- product technical training
- warranty support
- support service agreements

Download up to date manuals and ladder logic files at
<http://www.helminstrument.com/manuals-and-downloads/>

Your Questions or Comments on this Manual

If you have any suggestions for how this manual could be made more useful to you, please send us your ideas.