



Helm Instrument Company, Inc.
361 West Dussel Drive
Maumee, Ohio 43537 USA
Phone: 419-893-4356
Fax: 419- 893-1371
www.helminstrument.com

Installation Instructions
HM1734-PLM-Rev511
POINT I/O™ Strain Gage Input Module
POINT I/O is a trademark of Rockwell Automation

November, 2022

Process Control Systems, Instruments and Transducers

Visit our Web Site at <http://www.helminstrument.com> or email us at
sales@helminstrument.com

Revision 2.0
Copyright 2017 Helm Instrument Company, Inc.

Helm HM1734-PLM Installation Instructions

HELM INSTRUMENT COMPANY, INC. manufactures a complete line of load monitoring control solutions for use on metal stamping, forging, compaction and assembly presses, thermoforming, and tablet presses.

Standard or custom transducers and load cells are available for in-die monitoring of transfer or progressive tooling.

At HELM, quality is inherent not only in the design of our products but in the attitudes of our employees as well. We're working together to give you the best. After all, that's what our business is all about - providing innovative instrumentation to help make your manufacturing process more productive and your operation more effective.

The Helm HM1734-PLM is a single channel strain gage input module designed on the POINT I/O platform. The module is compatible with Allen-Bradley 1734-AENT Ethernet I/P and 1734-ACNR ControlNet adapters. The module can be directly connected to the 1769-L1x CompactLogix controllers.

The Helm HM173-PLM module features programmable high and low limits to protect the machine, the tooling and to ensure part quality.

A cam enable bit is available for high speed operations.

Strain Gage Transducers

The primary part of the load monitoring system centers around the measurement. The basic function of the Helm HT-400 Strain Gain sensor is to detect the amount of deflection imposed on the press or die as parts are being formed. All Strain Gain sensors are matched to within 1% and therefore can be replaced without recalibration of the machine.

The Helm Strain Gain sensors can be mounted to strategic high stress areas of the machine frame or strategically located in tooling or applied to stop blocks. Signals from these sensors are routed to the module for processing. The module is capable of measuring either a tension or compression signal.

Explosion Hazard

Do not disconnect equipment unless power has been removed or the area is known to be nonhazardous. Secure any external connections that mate to this equipment by using screws, sliding latches, threaded connectors, or other means provided with this product. Substitution of components may impair suitability for Class I, Division 2.

Preventing Electrostatic Discharge

This equipment is sensitive to electrostatic discharge, which can cause internal damage and affect normal operation. Follow these guidelines when you handle this equipment.

Touch a grounded object to discharge potential static.

- Wear an approved grounding wrist strap.
- Do not touch connectors or pins on component boards.
- Do not touch circuit components inside the equipment.
- If available, use a static-safe workstation. When not in use, store the equipment in appropriate static-safe packaging.

Grounding

POINT I/O is grounded through DIN rail to chassis ground. Use zinc plated, yellow chromated steel DIN rail to assure proper grounding. Using other DIN rail materials (e.g. aluminum, plastic, etc.) which can corrode, oxidize or are poor conductors can result in improper or intermittent platform grounding.

Helm HM1734-PLM Installation Instructions

Installing the Mounting Base

To install the mounting base on the DIN rail, proceed as follows

1. Position the mounting base vertically above the installer units adapter, power supply or existing module.
2. Slide the mounting base down allowing the interlocking side pieces to engage the adjacent module or adapter.
3. Press firmly to seat the mounting base on the DIN rail. The mounting base will snap into place.
4. To remove the mounting base from the DIN rail, remove the module, and use a small bladed screwdriver to rotate the base locking screw to a vertical position. This releases the locking mechanism. Then lift straight up to remove.

POINT I/O One-piece Terminal Bases 5

Install a Base

To install a base on DIN rail, proceed as follows, referring to the figures to identify major parts of the base.

1734-TOP and 1734-TOPS

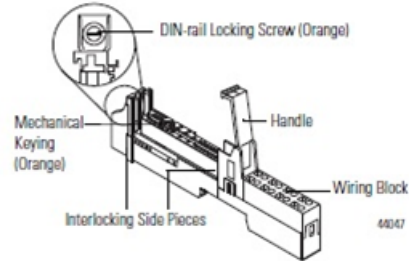

Installing the I/O module

The module can be installed before, or after base installation. Make sure that the mounting base is correctly keyed before installing the module into the mounting base. In addition, make sure the mounting base locking screw is positioned horizontal referenced to the base.

When you insert or remove the module while backplane power is on, an electrical arc can occur.

1734-TOP3 and 1734-TOP3S

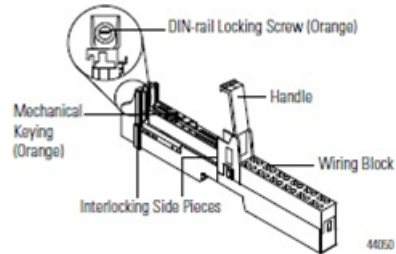

Installing the Removable Terminal Block (RTB)

A removable terminal block is supplied with your wiring base assembly. To remove, pull up on the RTB handle. This allows the mounting base to be removed and replaced as necessary without removing any of the wiring. To reinsert the removable terminal block, proceed as follows.

1. Insert the end opposite the handle into the base unit. This end has a curved section that engages with the wiring base.
2. Rotate the terminal block into the wiring base until it locks itself in place.
3. If an I/O module is installed, snap the RTB handle into place on the module.

When you connect or disconnect the RTB with field side power applied, an electrical arc can occur. This could cause an explosion in hazardous location installations. Be sure that power is removed or the area is nonhazardous before proceeding.

Helm HM1734-PLM Installation Instructions

Removing a Mounting Base

To remove a mounting base, you must remove and installed module, and the module installed in the base to the right. Remove the removable terminal block (if wired).

1. Unlatch the RTB handle on the I/O module.
2. Pull on the RTB handle to remove the removable terminal block.

When you connect or disconnect the RTB with field side power applied, an electrical arc can occur. This could cause an explosion in hazardous location installations. Be sure that power is removed or the area is nonhazardous before proceeding.

3. Press on the module lock on the top of the module.
4. Pull on the I/O module to remove from that base.

When you insert or remove the module while backplane power is on, an electrical arc can occur. This could cause an explosion in hazardous location installations. Be sure that power is removed or the area is nonhazardous before proceeding.

5. Repeat steps 1, 2, 3, 4 for the module to the right.
6. Use a small bladed screwdriver to rotate the orange base locking screw to a vertical position. This releases the locking mechanism.
7. Then lift straight up to remove.

Helm HM1734-PLM Installation Instructions

COMMUNICATION WITH THE MODULE

I/O messages are sent to (consumed) and received from (produced) the POINT I/O modules. These messages are mapped into the processor's memory. This POINT I/O input module produces 2 bytes of input data (scanner Rx) and 2 bytes of output data (scanner Tx).

NEED: HM1734_PLM_REV511_V20, ACD LADDER LOGIC

SETTING UP HM1734-PLM MODULE USING 1734-AENT/A on Ethernet/IP

General Tab Settings

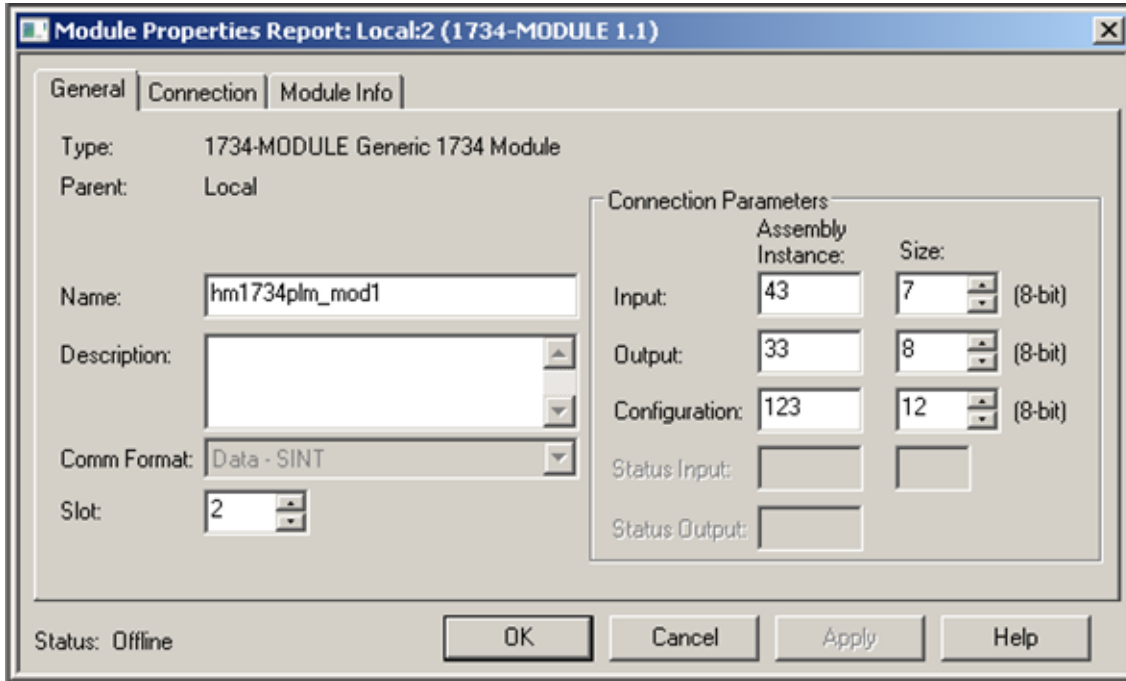

Connection Tab Settings

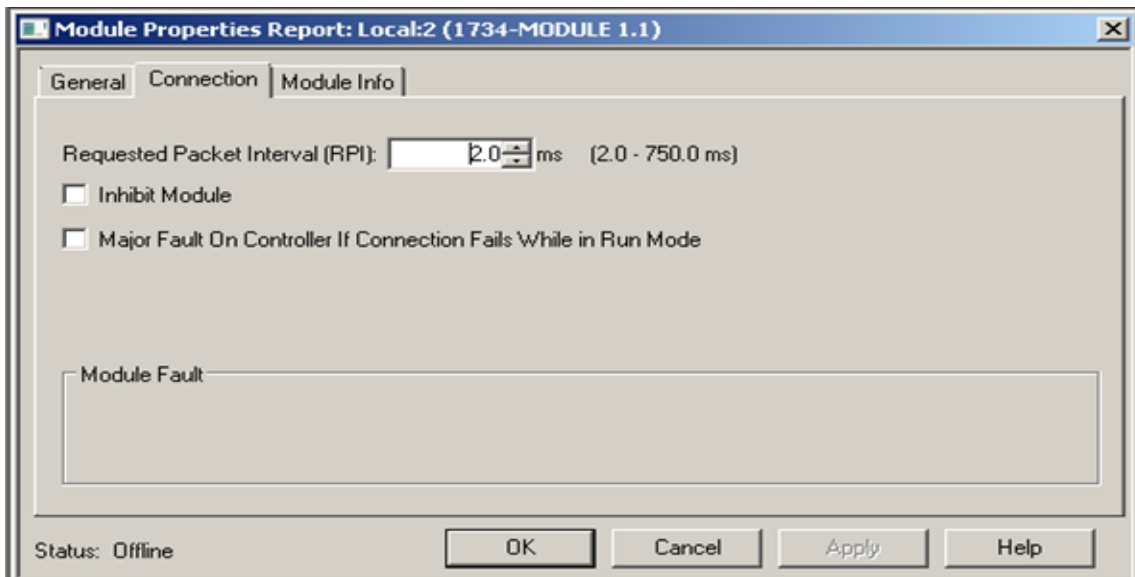

Helm HM1734-PLM Installation Instructions

Data Map for HM1734-PLM on Ethernet/IP

INPUT DATA TAGS

Data Tags name:x.l	Data Type	Bit	Description
.Data[4]	SINT	-	CH1 Value LSByte
.Data[5]	SINT	-	CH1 Value MSByte
.Data[6]		5	High Alarm Bit
.Data[7]		6	Low Alarm Bit

x: Point I/O slot position of HM1734-PLM.

OUTPUT TAGS

[n] = slot number for module		
LOCAL:[n]:O.Data	SINT[2]	Description
LOCAL:1:O.Data[0]	SINT	
LOCAL:1:O.Data[0].0	bit	Track Mode
LOCAL:1:O.Data[0].1	bit	Peak Mode
LOCAL:1:O.Data[0].2	bit	Ch1 Clear Tare Bit (momentary)
LOCAL:1:O.Data[0].3	bit	Ch1 Tare Bit (momentary)
LOCAL:1:O.Data[0].4	bit	Alarm Reset
LOCAL:1:O.Data[0].5	bit	Set Cal Factor
LOCAL:1:O.Data[0].6	bit	Read Cal Factor
LOCAL:1:O.Data[0].7	bit	Reverse Load
LOCAL:1:O.Data[1]	SINT	
LOCAL:1:O.Data[1].0	bit	External Cam Enable
LOCAL:1:O.Data[1].1	bit	Bypass Scaling
LOCAL:1:O.Data[1].2	bit	Save to EEPROM
LOCAL:1:O.Data[1].3	bit	Cam Bit
LOCAL:1:O.Data[1].4	bit	Restore Cal Factor

Data Map for HM1734-PLM on Ethernet/IP

Required Controller Tags

Data Tags Name	Data Type	
	INT[9]	
hicapset	INT	High Capacity Alarm Setting
lowcapset	INT	Low Capacity Setting
peakload	INT	Peak Load
set_ref_tons	INT	Set Reference Tons
	BOOL[2]	
hicapalarm	BOOL	High Capacity Alarm Bit
locapalarm	BOOL	Low Capacity Alarm Bit

Helm HM1734-PLM Installation Instructions

OUTPUT TAG DESCRIPTIONS

TRACK MODE

Ethernet/IP (Data[0]): Bit 0

Used for initial installation

PEAK MODE

Ethernet/IP (Data[0]): Bit 1

A/D values scaled with math in ladder logic

CLEAR TARE BIT

Ethernet/IP (Data[0]): Bit 2

Clears internal tare value for "zero state".

Useful when troubleshooting load cell wiring or other failures.

TARE

Ethernet/IP (Data[0]): Bit 3

Sets A/D value to zero.

ALARM RESET

Ethernet/IP (Data[0]): Bit 4

SET CAL FACTOR (IN PEAK MODE ONLY)

Ethernet/IP (Data[0]): Bit 5

READ CAL FACTOR (IN PEAK MODE ONLY)

Ethernet/IP (Data[0]): Bit 6

EXTERNAL CAM ENABLE

Ethernet/IP (Data[1]): Bit 0

Set bit to use external cam input.

BYPASS SCALING

Ethernet/IP (Data[1]): Bit 1

SAVE TO EEPROM

Ethernet/IP (Data[1]): Bit 2

Use to save all settings to module

CAM BIT

Ethernet/IP (Data[1]): Bit 3

PLC cam bit used when external cam is disabled.

RESTORE CAL FACTOR

Ethernet/IP (Data[1]): Bit 4

Helm HM1734-PLM Installation Instructions

REQUIRED CONTROLLER TAGS

SET REFERENCE TONS

Full scale setting for CH1

Value is determined by capacity of load cell and by resolution required.

Actual value is from load cell specification or rated capacity on column or side of press.

LOW CAPACITYALARM SET

Enter desired value to set low alarm limit.

PEAK LOAD

Reports measured peak tonnage value in RUN mode.

Reports raw A/D count value in CAL mode.

HIGH CAPACITY SETTING

Enter desired value to set high alarm limit.

HIGH CAPACITY ALARM BIT

Bit is set when high limit is reached

LOW CAPACITY ALARM BIT

Bit is set when low limit is reached.

REVERSE LOAD

Reports measured reverse load (snap-thru).

Helm HM1734-PLM Installation Instructions

Troubleshooting with the Indicators

Module Status:

Off	No power applied to device.
Green	Device operating normally.
Flashing Green	Device needs commissioning due to configuration missing, incomplete or incorrect.
Flashing Red	Recoverable fault.
Red	Unrecoverable fault. May require device replacement.
Flashing Red/Green	Device is in self-test.

Network Status:

Off	Device is not on-line. Device has not completed dup_MAC_id test. Device not powered. Check module status indicator.
Green	Device on-line and has connections to the established state.
Flashing Green	Device is on-line but has no connections in the established state.
Flashing Red	One or more I/O connections is in timed-out state.
Red	Critical link failure – failed communications device.
Flashing Red/Green	Network access error and is in communication faulted state. Device has received and accepted an Identity Communication Faulted Request – long protocol message.

Helm HM1734-PLM Installation Instructions

Setup Procedure

A complete listing of a sample ladder logic program is included at the back of this manual. Examples shown here are for reference.

All values are 0 (default) on initial start-up.
This means that all alarms are disabled.
You must make the following adjustments for proper operation:

- Balance sensor input(s)
- Set Calibration numbers

Step 1. Balance Sensor Input

1. Set to TRACK mode.
2. Set Clear Tare bit momentarily and set check coarse zero bit.
3. Check Raw A/D value. 32,000
CH1 = Controller Tag "value".
4. Set Zero Tare bit momentarily.

Step 2. Set Calibration Factor

1. Set to Peak Mode.
2. Set Reference Tons to Actual Load/Tons.
3. Run Machine.
4. Toggle Set Cal Factor bit.
5. Value should Equal Load/Tons.
6. Set to Track Mode.
7. Toggle Save to EEprom bit.
8. Set to Peak Mode.
9. Set Read Cal Factor bit to Record Cal Factor on Calibration Sheet.

Extra Step: Restore Cal Factor

Use to restore Cal Factor when swapping modules.

1. Set to Track Mode.
2. Enter recorded Cal Factor value on calibration sheet at Reference Tons.
3. Set Cal Factor to Restore bit.
4. Toggle "Save to EEprom" bit.
5. Clear Set Cal Factor Restore bit.
6. Enter normal Reference Tons.
7. Toggle "Save to EEprom" bit.

Helm HM1734-PLM Installation Instructions

Specifications - HM1734-PLM Strain Gage Input Module

Module Location	1734-TOP (screw terminal) or 1734-TOPS (spring loaded terminal)
Type of input	Strain Gage (350 ohm, 700 ohm)
Gage Excitation Voltage	5V
Input Impedance	1 meg. ohm
Display Resolution	.1% of full scale
Module Accuracy	Dependent on Load Cell Specification
Module Update Time	Software selectable from 2ms to 100ms
Number of Channels	1
A/D Conversion Method	Successive Approximation - 12 bit
Normal Mode Rejection: (between +/- input)	116DB CMRR
Amplifier Bandwidth	200 kHz
Calibration	Software Selectable
Isolation:	500 VDC continuous between inputs and chassis ground, and between input and backplane
LED indicators	2 LED's for Power and Alarm
Recommended Cable	Strain Gage Cable (Helm part number 6117)
Operating Temperatures	0°C to 60°C (32°F to 140°F)
Emissions	CISPR 11 Group 1, Class A
Pointbus Current	5V @ 72ma
External Power	24V @ 19.5ma
Voltage Range	10-28.8V dc
Dimensions	2.21H x 0.47W x 2.97L (Millimeters 56H x 12W x 75.5L)

HM-1734-PLM Point I/O Wiring Connections

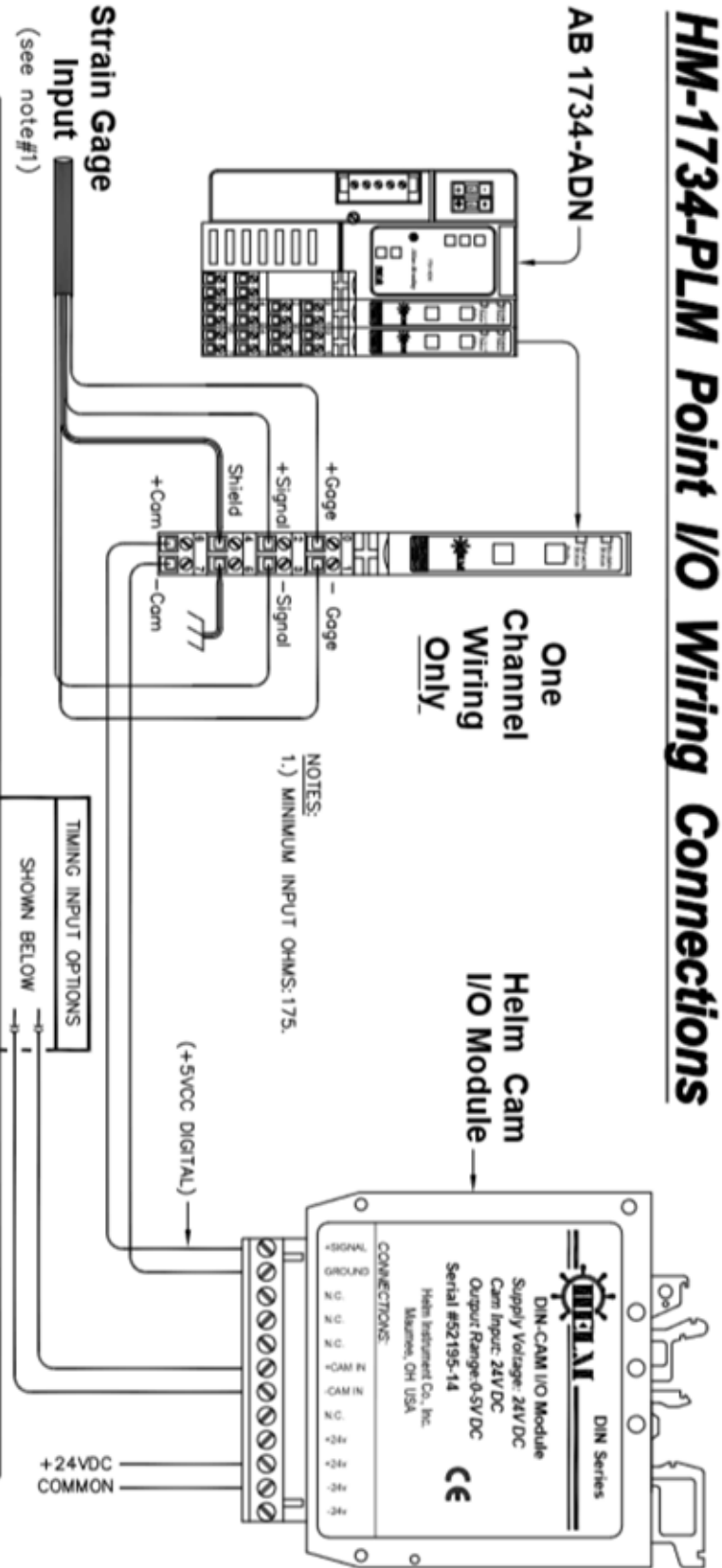

EXTERNAL DRY-CONTACT CAM SWITCH	24 VDC PLC OUTPUT	EXTERNAL 2-WIRE PROX PROBE	EXTERNAL 3-WIRE PROX PROBE	TRANSISTOR-TYPE OUTPUT



THIS DRAWING AS WELL AS THE SUBJECT MATTER THEREON IS EXCLUSIVE PROPERTY OF HELM INSTRUMENT CO., INC. IT IS TO BE TREATED BY YOU AS CONFIDENTIAL, PROPRIETARY INFORMATION. THE DRAWING OR SUBJECT MATTER THEREOF SHALL NO BE DUPLICATED OR DISCLOSED WITHOUT THE EXPRESS WRITTEN CONSENT OF HELM INSTRUMENT CO., INC.

SCALE: 3/4	DESIGNED BY: N.F.N.	DRAWN BY: M.H.L.
DATE: 04/01/14	CHECKED BY: N.F.N.	APPROVED BY: R.J.G.
TITLE: SENSOR CONNECTIONS, HM-1734-PLM (HELM)		
DRAWER:	DRAWING NUMBER: E1133W07	